



SERVERS

Master Switch

Master Switch



MASTER SWITCH is a static transfer switch commonly used within power continuity applications to improve resilience. The system can be used in conjunction with UPS or as separate standalone devices.

OPERATING PRINCIPLE

MASTER SWITCH adds a source of redundancy to a critical installation and automatically transfers the connected load between two separate AC power sources. The transfer can be automatic when an input power

supply fails outside set tolerances or be manually forced using the front panel keypad or remotely via a communications network.

PROTECTION AGAINST POWER FAILURES

In the event that one of the two power sources does not return to the accepted tolerance values, the **MASTER SWITCH** will transfer the other loads over to the second power source (this happens instantly if the two sources are in phase).

The complete range of power solutions

Uninterruptible Power Supplies, Central Battery Supply Units, Static Transfer Switches, Generators and Inverters



PROTECTION AGAINST ENVIRONMENTAL DISTURBANCES OVERLOADS AND LOAD FAULTS

In the event of an overload or fault condition, the internal protection system within the STS device can be configured to disconnect power at defined levels. In the extreme situation of a downstream short circuit **MASTER SWITCH** can disconnect the load to prevent disruption.

CHARACTERISTICS

- Full protection of critical industrial and IT applications against power failures and faults on the load.
- Full microprocessor control which guarantees:
 - fast and safe transfer between the power sources.
 - monitoring of all parameters on the LCD display.
 - Constant control of the SCRs
 - Remote advanced diagnostics (RS232 and TCP/IP)
- Redundant power circuits:
 - Power is supplied to the internal logic by two separate and independent power circuits that are hot swappable so as to ensure no break in the supply to the loads.
 - In the event that the power supplied by both sources fails, full system operation is guaranteed by the Power Supply Backup function that provides backup power to the circuits from an external, independent standby power source.
- High protection
 - In the event of an output short circuit, MASTER SWITCH will block the transfer between the two power sources eliminating the risk of propagating the short circuit and its effects on the other loads.
 - A backfeed control circuit will trigger automatic protection devices to avoid energy feeding back to one of the inputs of the MASTER SWITCH.
 - MASTER SWITCH has double redundant ventilation called "fan redundancy plus". Thanks to this function, in the remote possibility that two fans both fail at the same time, the others would still be able to dissipate the heat generated at nominal load. The fans can be hot swapped so as to ensure no break in system operation during the repair.
- Easy front access
 - power cable connections are easily accessed with entry from below
 - board slots are positioned in a dedicated area to allow rapid diagnosis/replacement
 - all parts subject to controls, maintenance and/or replacement.

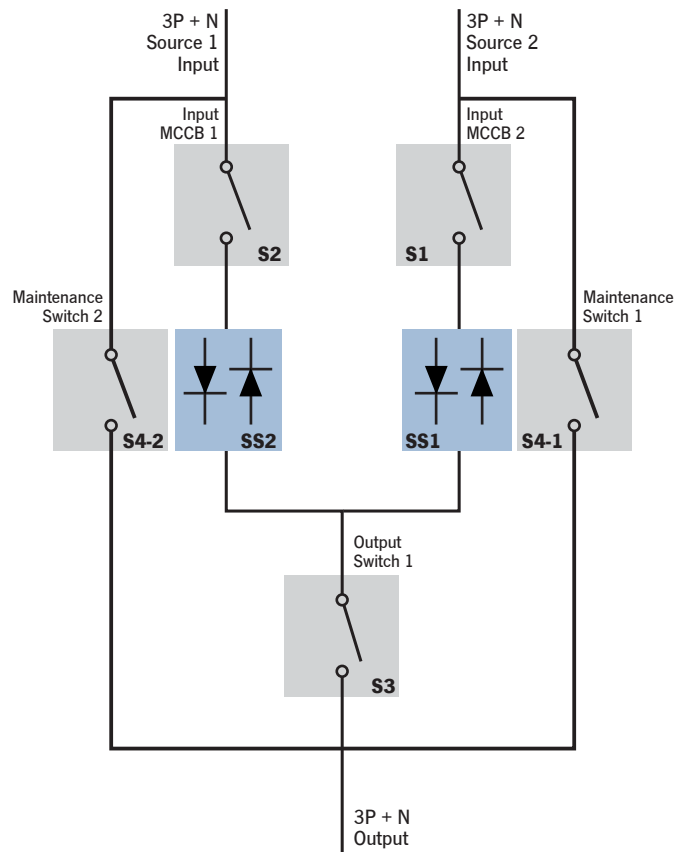

Master Switch

Display

LED	FUNCTION
L1	S1 Priority source
L2	S2 Priority source
L3	S1 Present
L4	S2 Present
L5	Static switch SS1 closed
L6	Static switch SS2 closed
L7	Alarm indicator
L8	Output selection ON/OFF

5 function keys and LCD operations

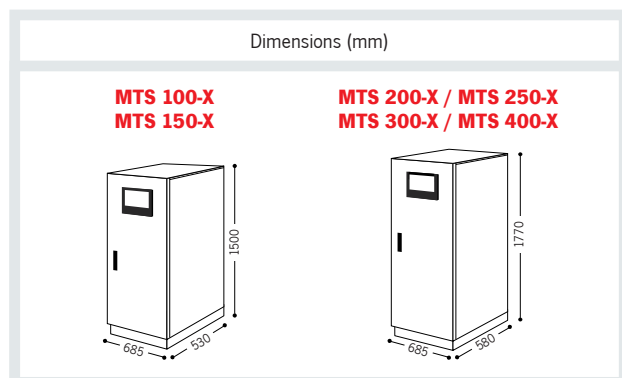

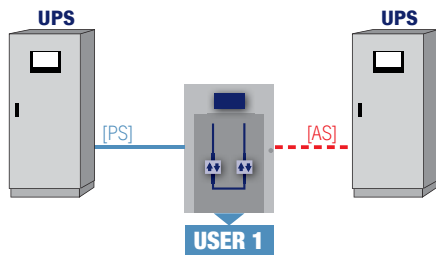

MASTER SWITCH in

REDUNDANT Mode

The reliable secondary source [AS] will power the load only and exclusively when the primary source (PS) fails, so as to guarantee maximum redundancy and quality of the power supply to the loads.

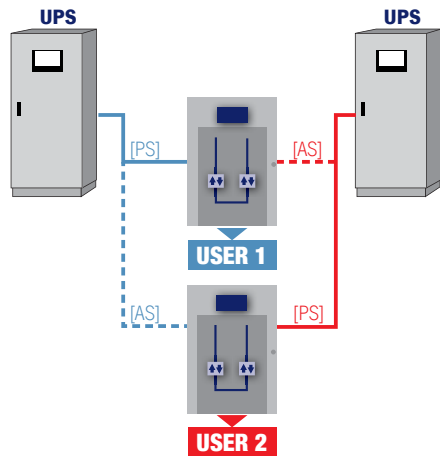

MASTER SWITCH in

CROSS FEEDING Mode

The two sources power a number of critical loads using the MASTER SWITCHES configured in such a way as to make one of the two power sources the priority source (PS). In cases of power faults or failure on one of the two sources, the other one will be able to supply power to all the loads connected to the system.

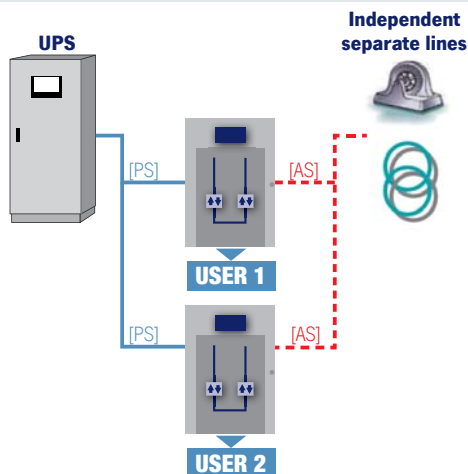

MASTER SWITCH in

BACK UP Mode

MASTER SWITCH powers a number of loads using the priority source (PS). The secondary source (AS) is formed by independent and separate sources which can supply standby power should the priority source (PS) fail suddenly

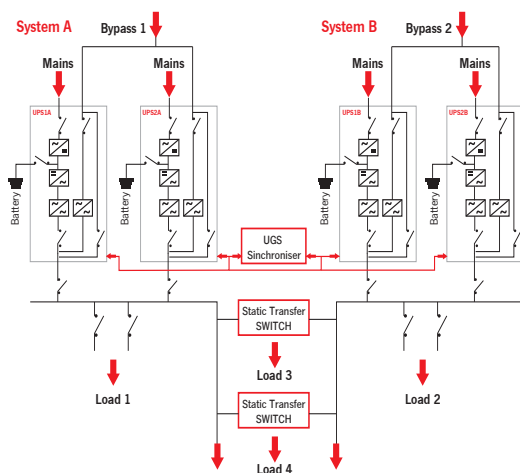

The solution offered by RIELLO UPS guarantees maximum reliability and ensures no break power supply in all operating conditions thanks to the UGS option that keeps the two systems A and B perfectly synchronised.

The flexibility of the UGS system is able to guarantee that the power sources remain synchronised even when one of the two systems is not a RIELLO UPS model but made by another manufacturer or when the input sources are not UPS's

MODELS (1)	MTS 100-X	MTS 150-X	MTS 200-X	MTS 250-X	MTS 300-X	MTS 400-X
NOMINAL CURRENT (A)	100	150	200	250	300	400
INPUT						
Nominal voltage - sources S1/S2	380 - 400 - 415 Vac 3-phases with neutral					
Input voltage tolerance	180±264 Vac (selectable)					
Switched input phases	3+N (4-pole) - 3 (3-pole)					
Nominal frequency	50/60 Hz					
Input frequency tolerance	+/-10% (selectable)					
Distribution compatibility	IT, TT, TNS, TNC					
OPERATING FEATURES						
Transfer typology	"Break Before Make" (no sources overlapping)					
Available transfer modes	Automatic / Manual / Remote					
Transfer time for source failure	< 4 msec (S1/S2 synchronised) 10 msec (S1/S2 not synchronised)					
ENVIRONMENTAL						
Efficiency at full load (%)	> 99					
Noise level at 1 m from front (from 0 to full load) - (dBA)	52		55	55	55	55
Storage temperature range	-10°C to +50°C					
Ambient temperature	0°C ÷ +40°C					
Relative humidity	90% non-condensing					
Max. Installation height	1000 m at rated power (-1% power for every 100 m above 1000 m) - Max 4000 m					
Standard compatibility	EN 62310-1 (safety) EN 62310-2 (electromagnetic compatibility)					
Dimensions (h x w x d) (mm)	1500 x 685 x 530			1770 x 685 x 580		
Weight (kg)	155	175	205	210	220	240
Colour	Light grey RAL 7035					
Index of protection	IP 20					

(1) X= 3 in cases of 3-pole switching (3 phases) ; X=4 in cases of 4-pole switching (3 phases + Neutral)

